

毅永企業有限公司 E-YUNG ENTERPRISE CO., LTD.

REV	ZONE	REVISION	DATE

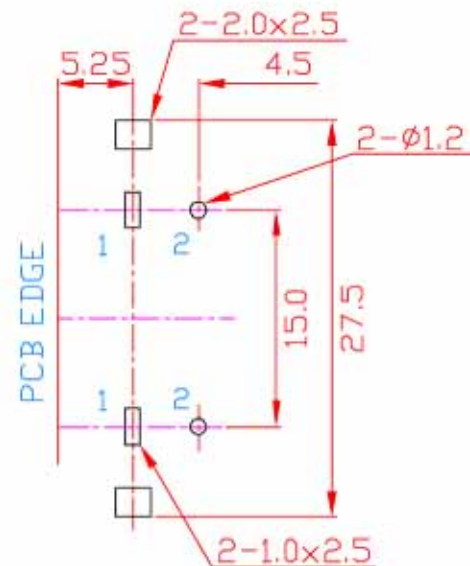
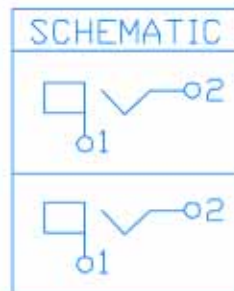
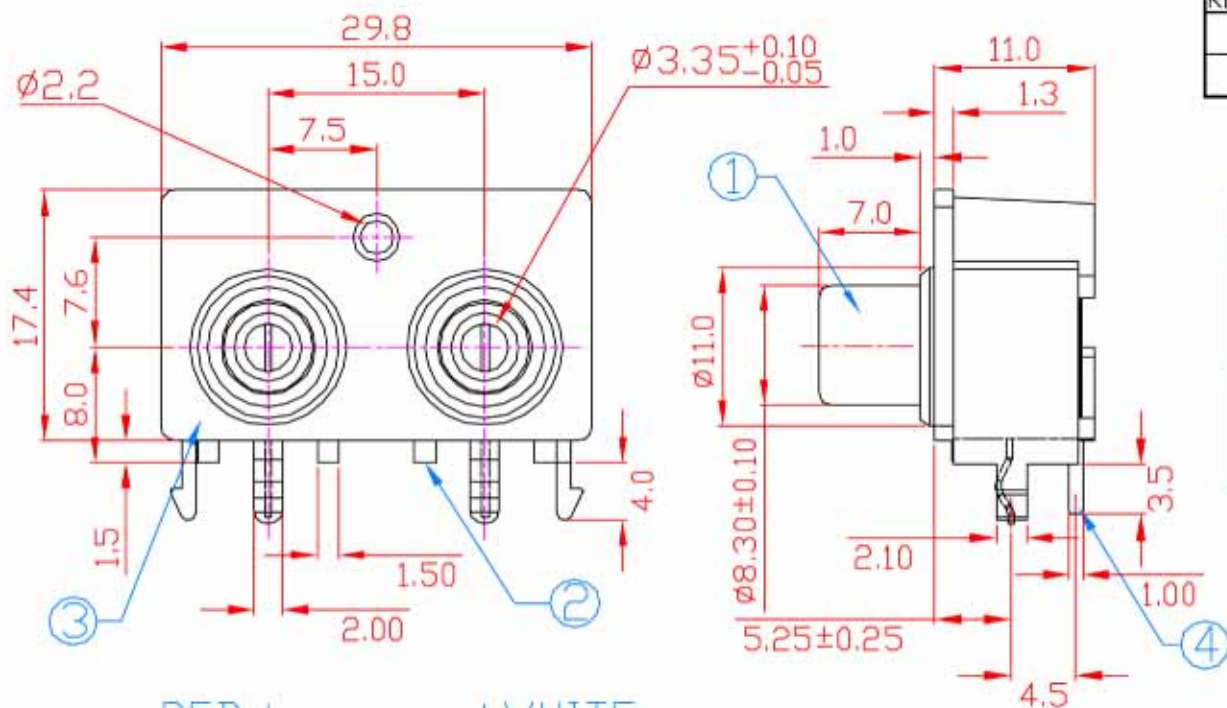

INSERT RING COLORS

Specification:

Contact Resistance: 30m Ohm. Max. At AC 100mA Max. 1KHz.

Insulation Resistance: 100M Ohm Min. At 500V DC.

Rated Voltage And Current: DC 12V, 2A Max ; AC 100V, 1A Max.

Dielectric Withstanding Voltage: 500VAC At 60Hz For 1 Minute

Durability (Life Test): 4000 Cycles .

Insertion Force: 0.3~3.0 Kg.

Extraction Force: 0.3~3.0Kg.

NO.	NAME	MATERIAL	FINISH	Q'TY
1	BARREL	BRASS T:0.40	NICKEL PLATED	2
2	JACK HOUSING	PBT G.F.	RED, WHITE	2
3	ASSEM. HOUSING	ABS	BLACK	1
4	CONTACT TERM.	BRASS T:0.50	TIN PLATED	2