

# 毅永企業有限公司 E-YUNG ENTERPRISE CO., LTD.

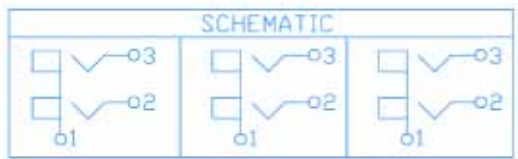

NO.	NAME	MATERIAL	FINISH	Q'TY
1	BARREL	BRASS T:0.4	NICKEL PLATED	3
2	INSERT RING	PBT G.F.	WHITE/RED	6
3	COVER	ABS	BLACK	3
4	HOUSING	ABS	WHITE	1
5	TERMINAL	BRASS T:0.5	TIN PLATED	3
6	TERMINAL	BRASS T:0.5	TIN PLATED	3

REV	ZONE	REVISION	DATE

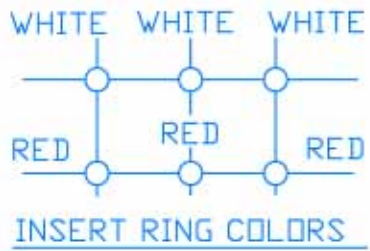
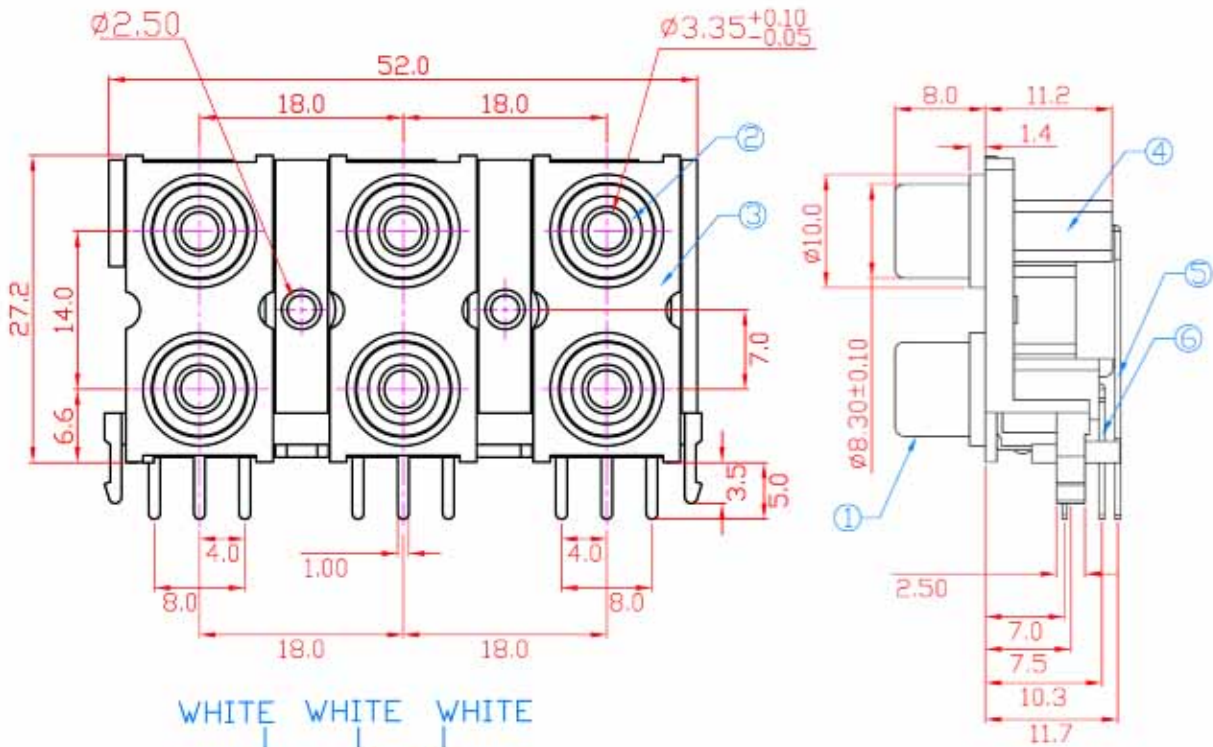
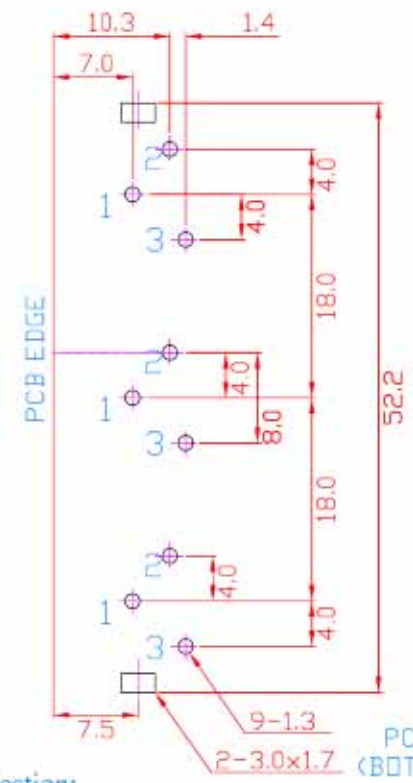

**Specification:**  
 Contact Resistance: 30m Ohm. Max. At AC 100mA Max. 1KHz  
 Insulation Resistance: 100M Ohm Min. At 500V DC  
 Rated Voltage And Current: DC 12V,2A Max ; AC 100V,1A Max.  
 Dielectric Withstanding Voltage: 500VAC At 60Hz For 1 Minute  
 Durability (Life Test): 4000 Cycles  
 Insertion Force: 0.3~3.0 Kg  
 Extraction Force: 0.3~3.0Kg