

毅永企業有限公司 E-YUNG ENTERPRISE CO., LTD.

REV	ZONE	REVISION	DATE

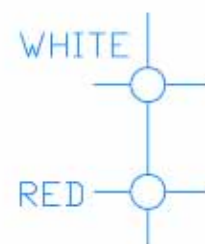
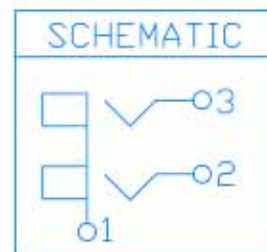
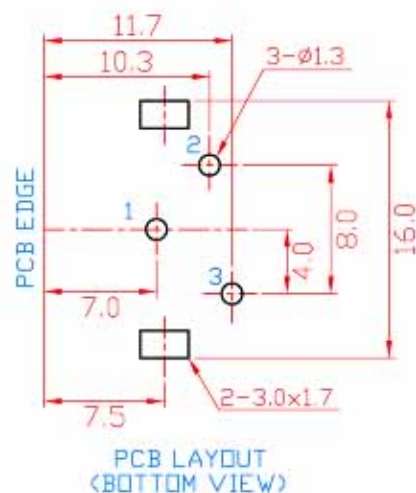
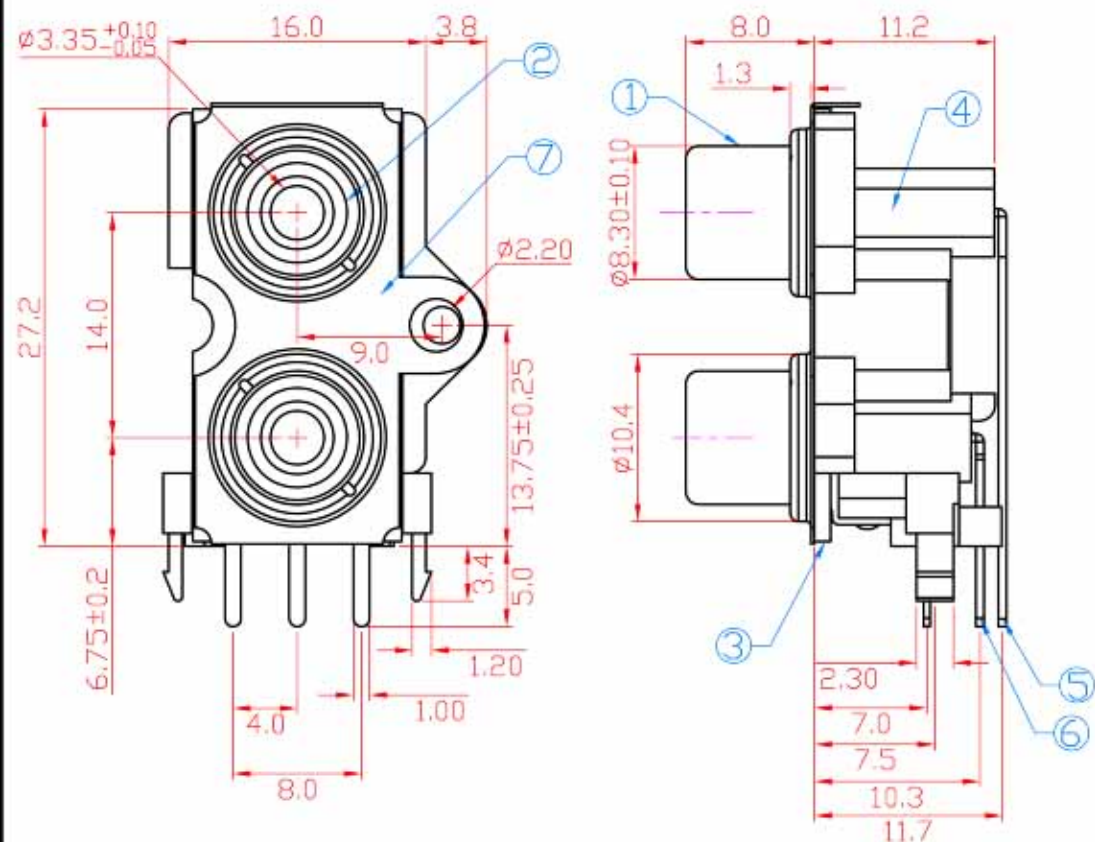

Specification:

Contact Resistance: 30m Ohm. Max. At AC 100mA Max. 1KHz.

Insulation Resistance: 100M Ohm Min. At 500V DC.

Rated Voltage And Current: DC 12V, 2A Max ; AC 100V, 1A Max.

Dielectric Withstanding Voltage: 500VAC At 60Hz For 1 Minute.

Durability (Life Test): 4000 Cycles.

Insertion Force: 0.3~3.0 Kg.

Extraction Force: 0.3~3.0 Kg.

NO.	NAME	MATERIAL	FINISH	Q'TY
1	BARREL	BRASS T:0.4	NICKEL PLATED	1
2	INSERT RING	PBT G.F.	RED, WHITE	2
3	COVER	ABS	BLACK	1
4	HOUSING	ABS	WHITE	1
5	TOP TERM.	BRASS T:0.5	TIN PLATED	1
6	BOTTOM TERM.	BRASS T:0.5	TIN PLATED	1
7	SHELL COVER	BRASS T:0.2	NICKEL PLATED	1