

# 毅永企業有限公司 E-YUNG ENTERPRISE CO., LTD.

REV	ZONE	REVISION	DATE

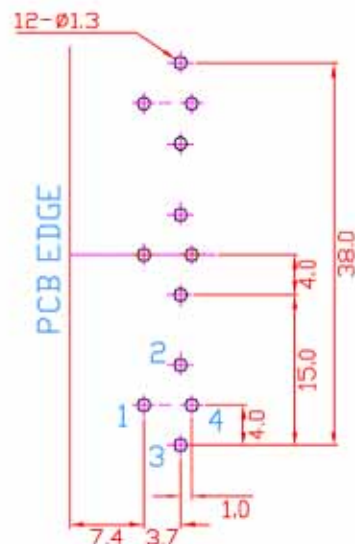
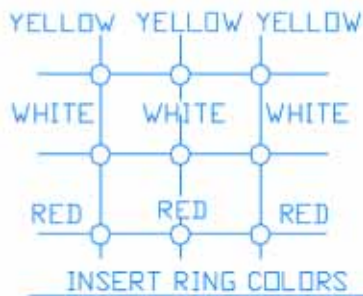
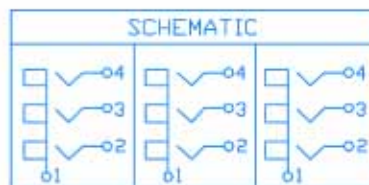
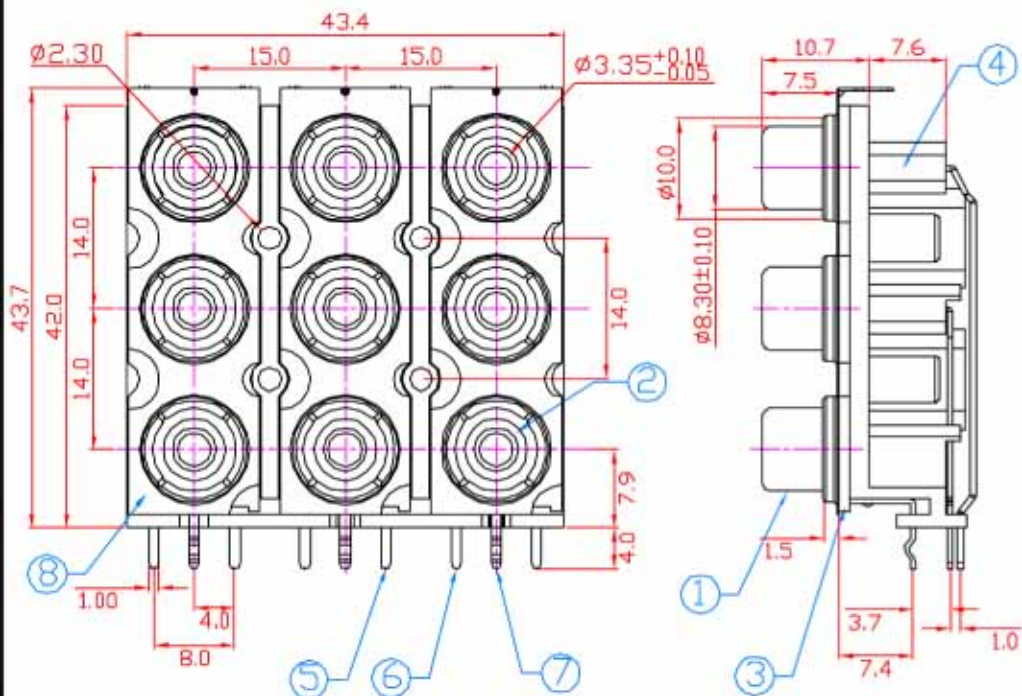

PCB LAYOUT (BOTTOM VIEW)

NO.	NAME	MATERIAL	FINISH	Q'TY
1	BARREL	BRASS T:0.4	NICKEL PLATED	3
2	INSERT RING	PBT G.F.	YELLOW/WHITE/RED	9
3	RETAINER	ABS	BLACK	3
4	HOUSING	ABS	YELLOW	1
5	TERMINAL	BRASS T:0.5	TIN PLATED	3
6	TERMINAL	BRASS T:0.5	TIN PLATED	3
7	TERMINAL	BRASS T:0.5	TIN PLATED	3
8	SHIELD COVER	BRASS T:0.2	NICKEL PLATED	3

## Specification:

Contact Resistance: 30m Ohm. Max. At AC 100mA Max. 1KHz  
 Insulation Resistance: 100M Ohm Min. At 500V DC  
 Rated Voltage And Current: DC 12V,2A Max ; AC 100V,1A Max.  
 Dielectric Withstanding Voltage: 500VAC At 60Hz For 1 Minute  
 Durability (Life Test): 4000 Cycles  
 Insertion Force: 0.3-3.0 Kg  
 Extraction Force: 0.3-3.0Kg