

毅永企業有限公司 E-YUNG ENTERPRISE CO., LTD.

REV	ZONE	REVISION	DATE

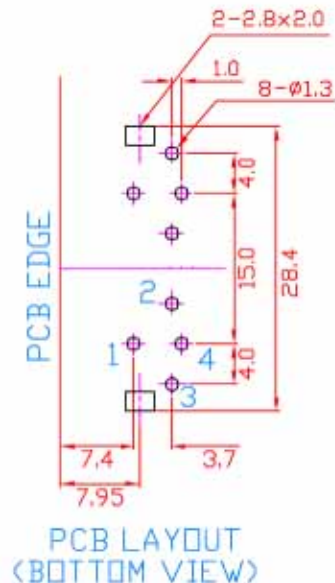
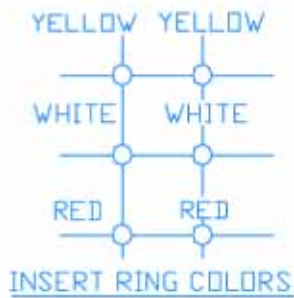
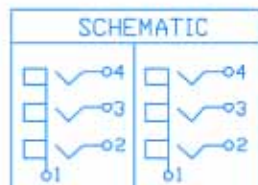
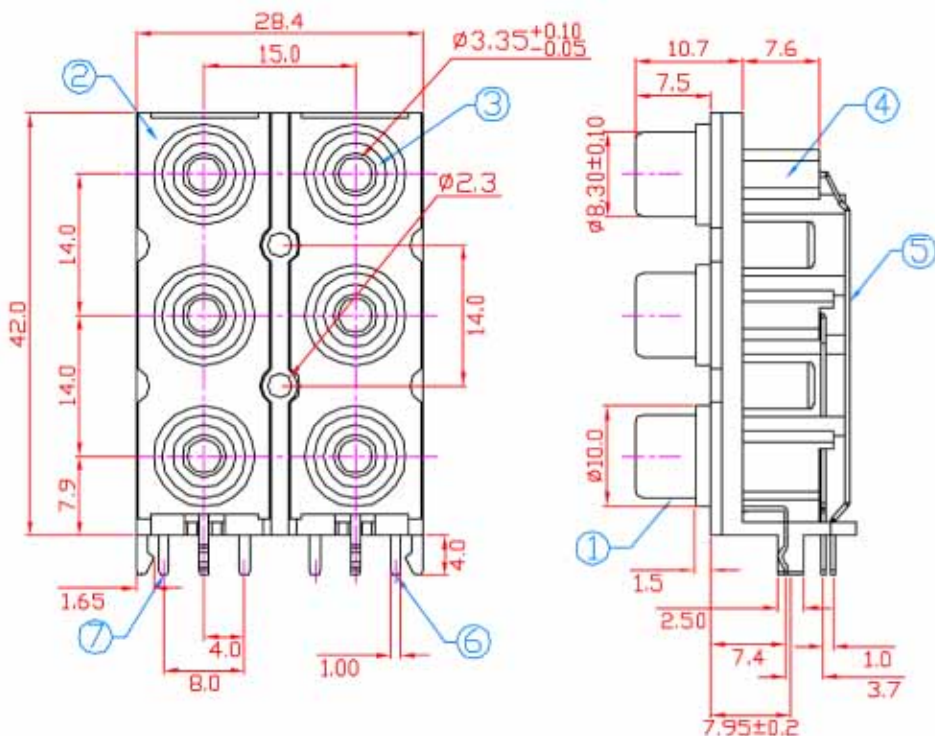

NO.	NAME	MATERIAL	FINISH	Q'TY
1	BARREL	BRASS T:0.40	NICKEL PLATED	2
2	INSERT RING	PBT G.F.	YELLOW/WHITE/RED	6
3	RETAINER	ABS	BLACK	2
4	HOUSING	ABS	YELLOW	1
5	TERMINAL	BRASS T:0.5	TIN PLATED	2
6	TERMINAL	BRASS T:0.5	TIN PLATED	2
7	TERMINAL	BRASS T:0.5	TIN PLATED	2

Specification:

Contact Resistance: 30m Ohm. Max. At AC 100mA Max. 1KHz
 Insulation Resistance: 100M Ohm Min. At 500V DC
 Rated Voltage And Current: DC 12V,2A Max ; AC 100V,1A Max.
 Dielectric Withstanding Voltage: 500VAC At 60Hz For 1 Minute
 Durability (Life Test): 4000 Cycles
 Insertion Force: 0.3~3.0 Kg
 Extraction Force: 0.3~3.0Kg