

# 毅永企業有限公司 E-YUNG ENTERPRISE CO., LTD.

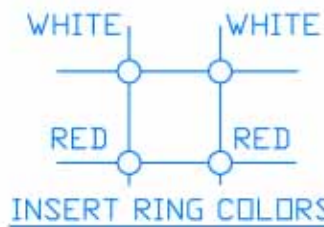

INSERT RING COLORS

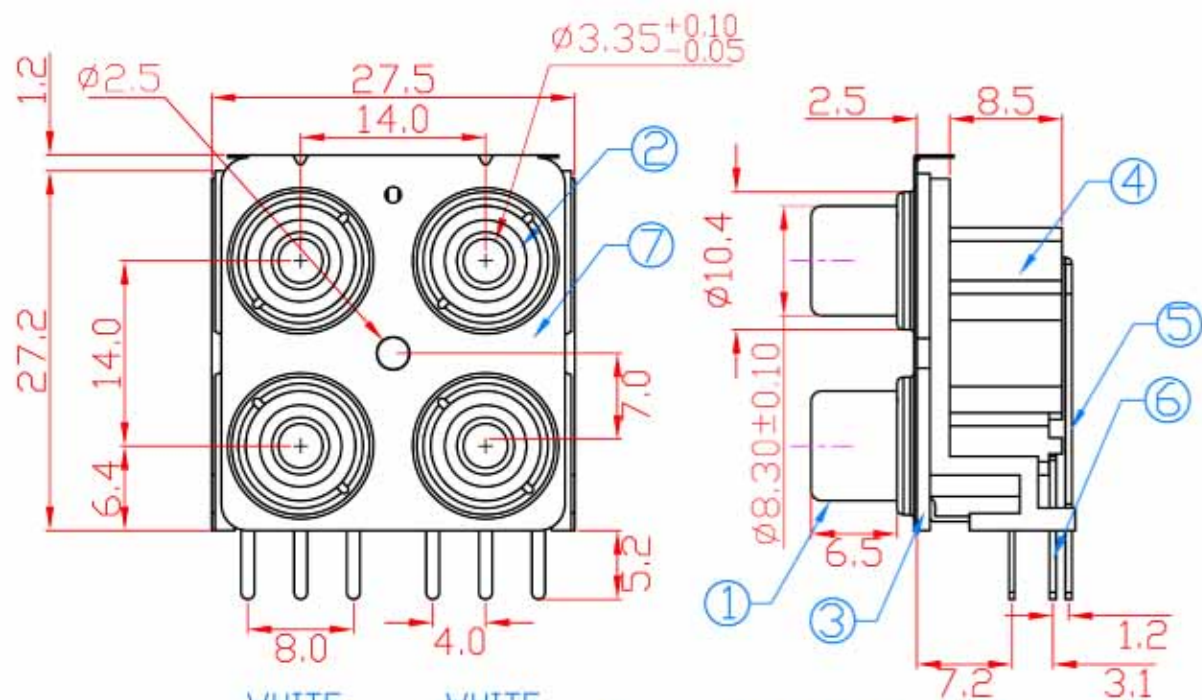
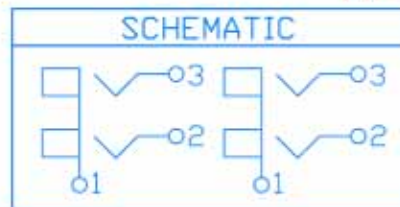

REV	ZONE	REVISION	DATE

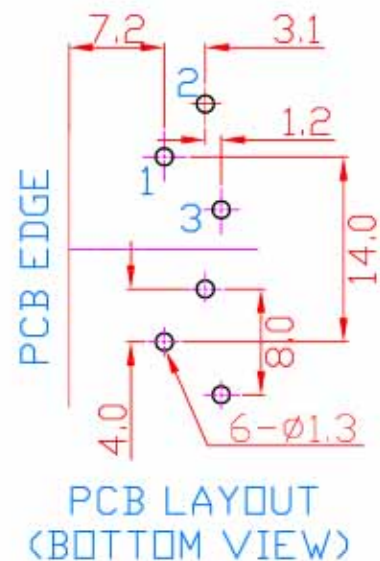

NO.	NAME	MATERIAL	FINISH	Q'TY
1	BARREL	BRASS 0.40	NICKEL PLATED	2
2	INSERT RING	PBT	WHITE/RED	4
3	COVER	ABS	BLACK	2
4	HOUSING	ABS	RED	1
5	POSITIVE	BRASS 0.50	TIN PLATED	2
6	POSITIVE	BRASS 0.50	TIN PLATED	2
7	SHEEL	BRASS 0.20	NICKEL PLATED	1

## Specification:

Contact Resistance: 30m Ohm. Max. At AC 100mA Max.1KHz.

Insulation Resistance: 100M Ohm Min. At 500V DC.

Rated Voltage And Current: DC 12V,2A Max ; AC 100V,1A Max.

Dielectric Withstanding Voltage: 500VAC At 60Hz For 1 Minute

Durability (Life Test): 4000 Cycles

Insertion Force: 0.3~3.0 Kg.

Extraction Force: 0.3~3.0Kg.