

毅永企業有限公司 E-YUNG ENTERPRISE CO., LTD.

| REV | ZONE | REVISION | DATE |
|-----|------|----------|------|
| | | | |

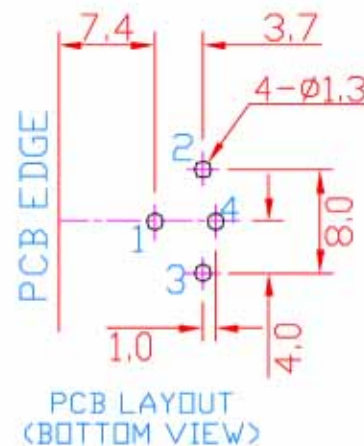
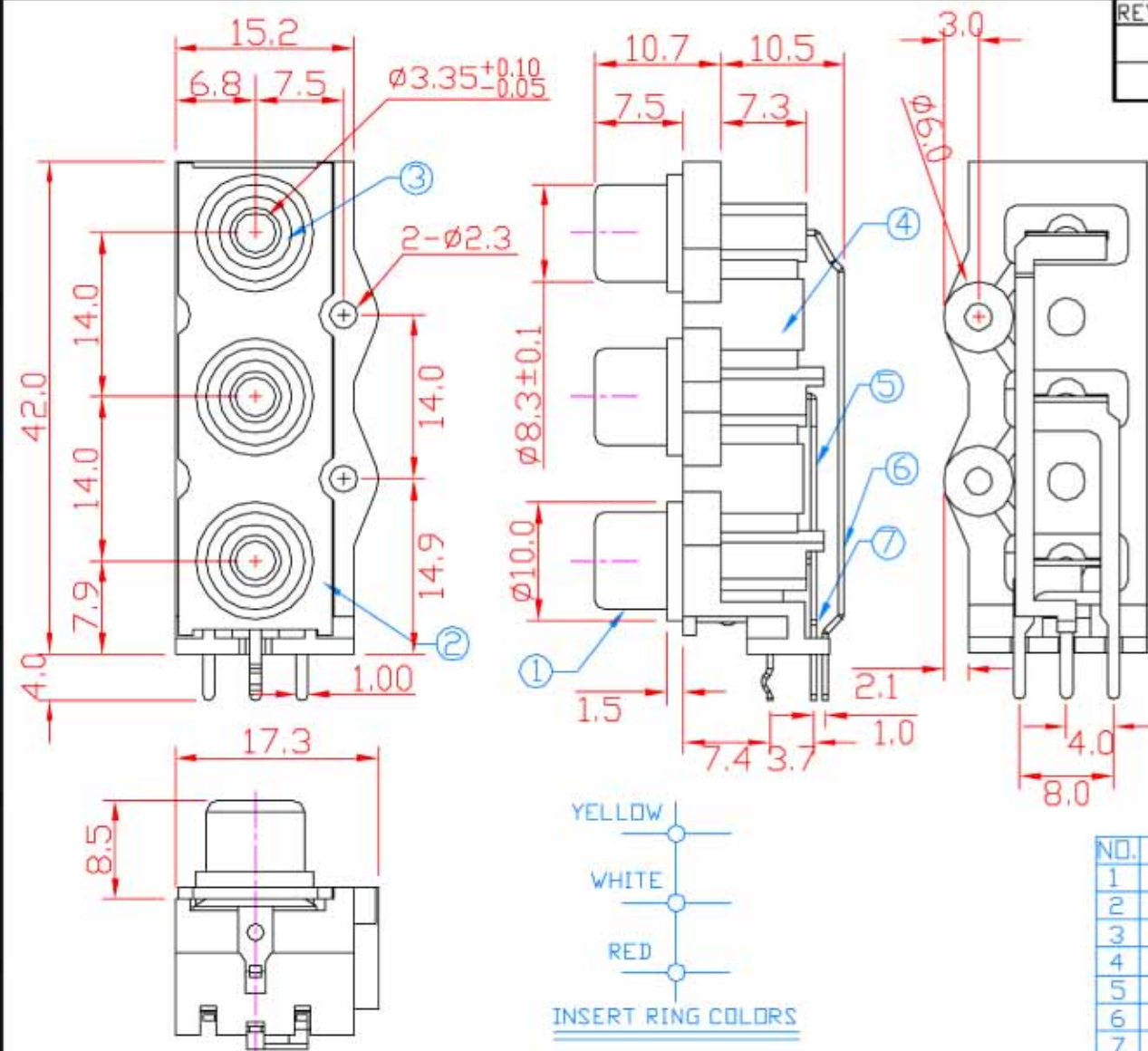

Specification:

Contact Resistance: 30m Ohm. Max. At AC 100mA Max. 1KHz.
 Insulation Resistance: 100M Ohm Min. At 500V DC.
 Rated Voltage And Current: DC 12V, 2A Max ; AC 100V, 1A Max.
 Dielectric Withstanding Voltage: 500VAC At 60Hz For 1 Minute
 Durability (Life Test): 4000 Cycles.
 Insertion Force: 0.3-3.0 Kg.
 Extraction Force: 0.3-3.0Kg.

| NO. | NAME | MATERIAL | FINISH | Q'TY |
|-----|-------------|------------|------------------|------|
| 1 | BARREL | BRASS 0.40 | NICKEL PLATED | 1 |
| 2 | COVER | ABS | BLACK | 1 |
| 3 | INSERT RING | PBT G.F. | YELLOW/WHITE/RED | 3 |
| 4 | HOUSING | ABS | YELLOW | 1 |
| 5 | TERMINAL | BRASS 0.50 | TIN PLATED | 1 |
| 6 | TERMINAL | BRASS 0.50 | TIN PLATED | 1 |
| 7 | TERMINAL | BRASS 0.50 | TIN PLATED | 1 |