

1 2 3 4 5 6 7 8

A A

B B

C C

D D

E E

F F

G G

H H

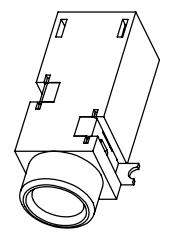
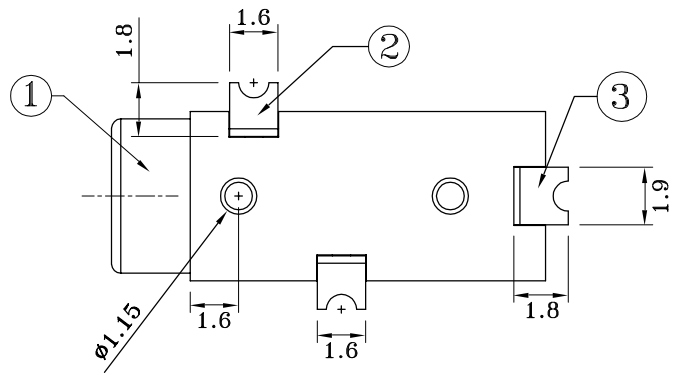
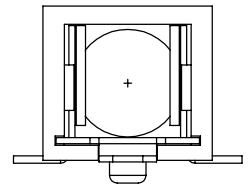
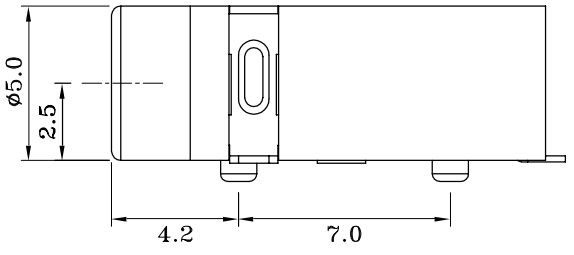
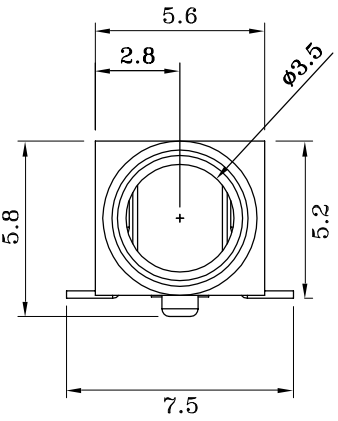
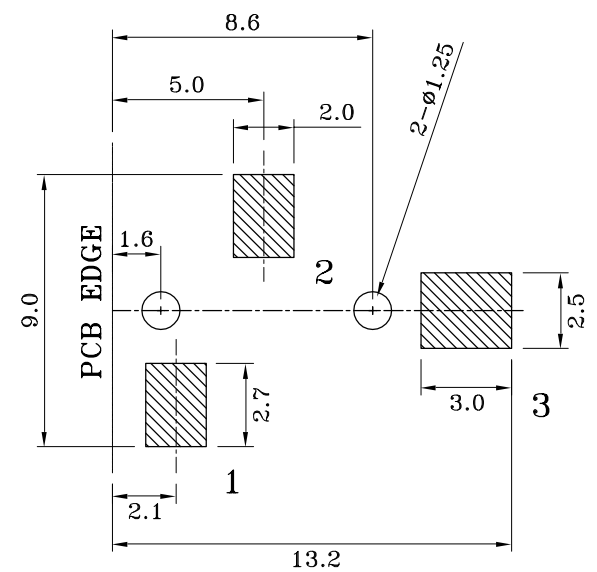
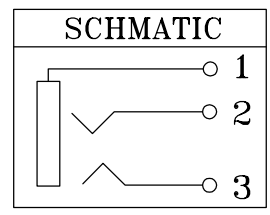
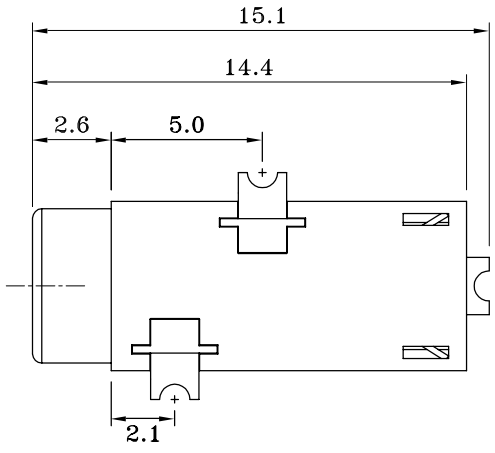

NO.	NAME	MATERIAL	FINISH	Q'TY
1	HOUSING	NYLON PA9T	BLACK	1
2	TERMINAL	BRASS T:0.2	TIN PLATED	2
3	TERMINAL	PHOS.BRONZE T:0.2	TIN PLATED	1

**E-YUNG**

E-YUNG ENTERPRISE CO., LTD.

MODEL	PJ-2502	PAGE 1 OF 1
-------	---------	-------------

COMPUTER NO.			UNIT	SCALE	PART NAME	
D:\DWG\PJ-2502			mm	4:1	3.5φ EAR PHONE JACK	
APPD.	CKD.	DWG.	DATE	TOLERANCE	PART NO.	REV.
		TINA	03-09-02	±0.3		B

1 2 3 4 5 6 7 8