

REV	ZONE	REVISION	DATE

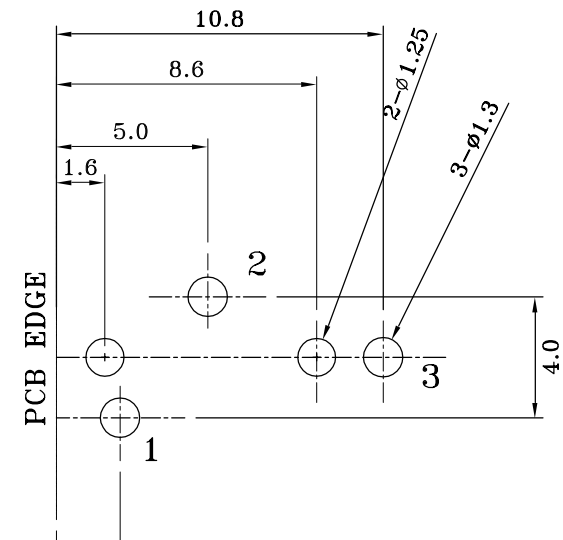

**RECOMMENDED
COMPONENT SIDE
(PCB LAYOUT)**

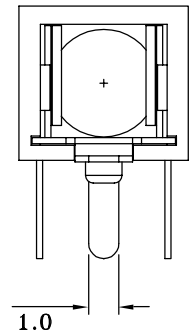
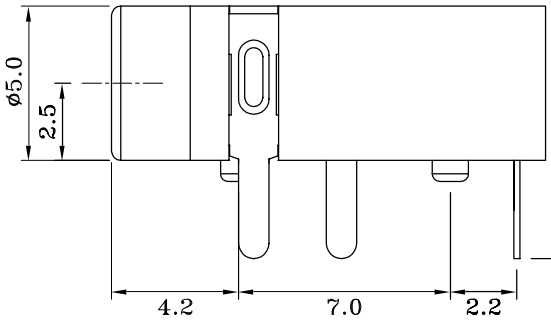
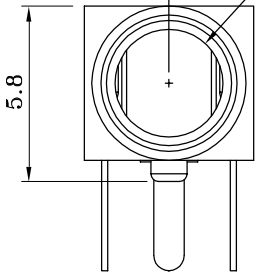
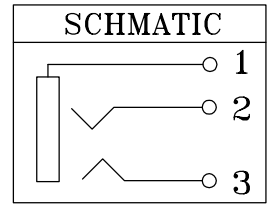
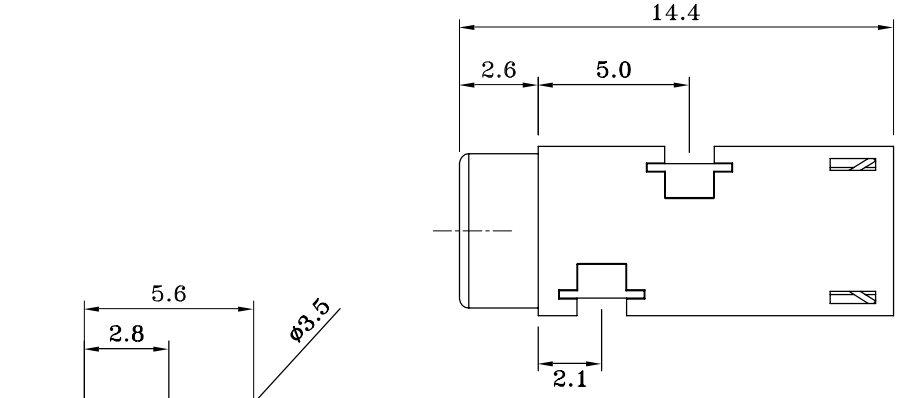
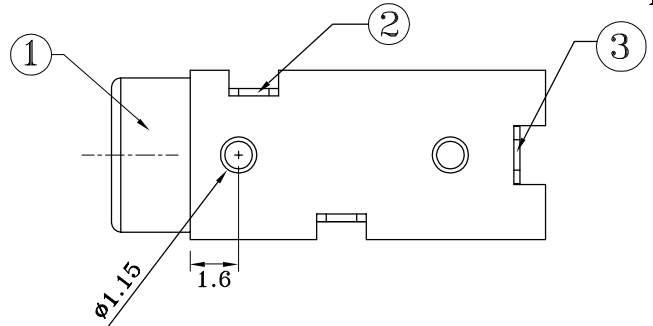
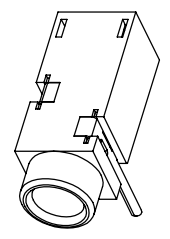

NO.	NAME	MATERIAL	FINISH	Q'TY
1	HOUSING	PBT	BLACK	1
2	TERMINAL	BRASS T:0.2	TIN PLATED	2
3	TERMINAL	PHOS.BRONZE T:0.2	TIN PLATED	1



E-YUNG ENTERPRISE CO., LTD.

COMPUTER NO.		UNIT	SCALE	PART NAME		
D:\DWG\PJ-2502-1		mm	4:1	3.5φ EAR PHONE JACK		
APPD.	CKD.	DWG.	DATE	TOLERANCE	PART NO.	REV.
		TINA	06-11-02	±0.3		B

MODEL PJ-2502-1 PAGE 1 OF 1