

# — 毅永企業有限公司 E-YUNG ENTERPRISE CO., LTD. —

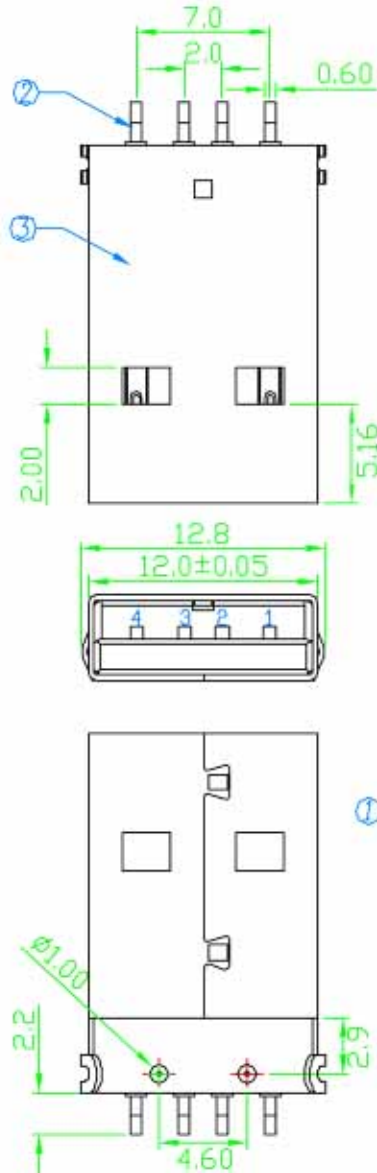

## Specification:

Contact Resistance: 30m Ohm Max.

Insulation Resistance: 1000M Ohm Min. At 500VDC.

Rated Voltage And Current: 1.5A At 250VAC Minimum.

Dielectric Withstanding Voltage: 750V AC (rms) for 1 Minute(Rev. 1.1)

Durability (Life Test): 1500 Cycles

Insertion Force: 35 Newton Maximum.

Extraction Force: 10 Newton Minimum.

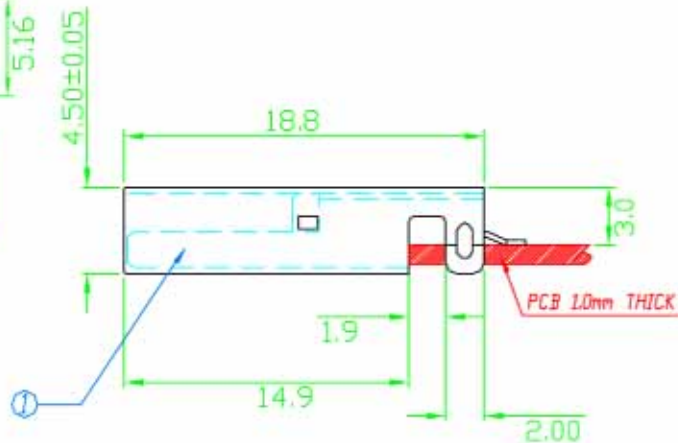

REV	ZONE	REVISION	DATE

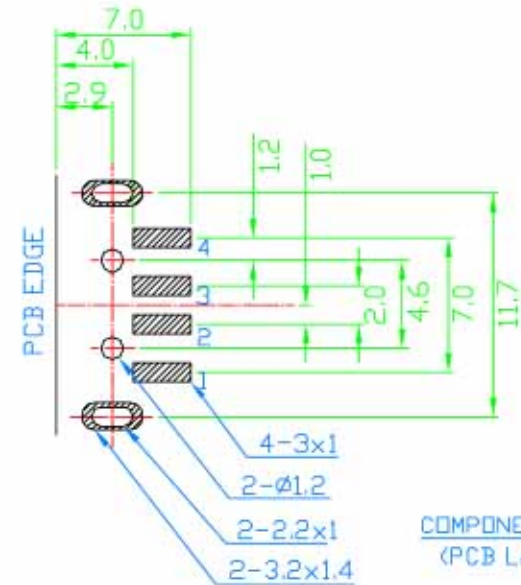

NO.	NAME	MATERIAL	FINISH	Q'TY	REMARK
1	HOUSING	NYLON PA9T G.F.	BLACK	1	
2	TERMINAL	BRASS E-H T:0.25	GOLD/TIN PLATED	4	Gold:1~3u', Ni:40~60u', TIN:120u' (100% pure Tin of lead free plating)
3	SHELL	BRASS T:0.3	NICKEL PLATED	1	Ni:80~120u'