

— 毅永企業有限公司 E-YUNG ENTERPRISE CO., LTD. —

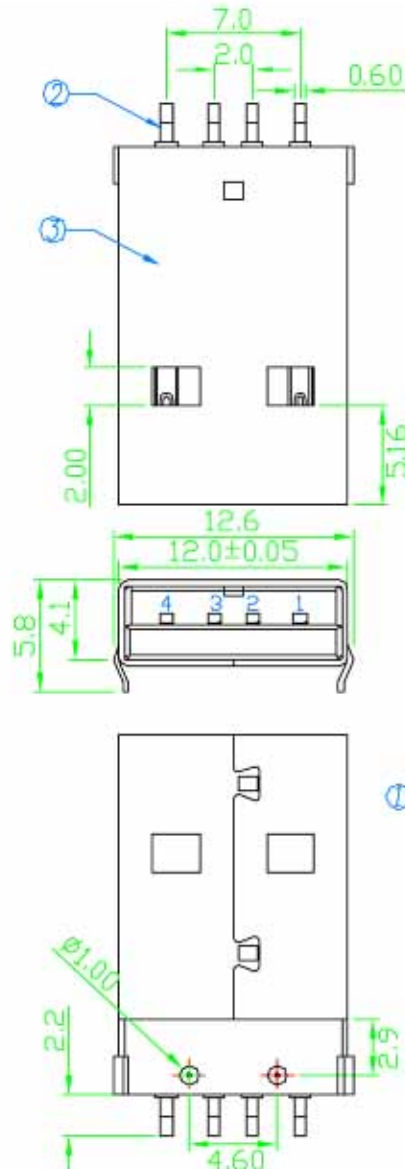

Specification:
 Contact Resistance: 30m Ohm Max.
 Insulation Resistance: 1000M Ohm Min. At 500VDC.
 Rated Voltage And Current: 1.5A At 250VAC Minimum.
 Dielectric Withstanding Voltage: 750V AC (rms) for 1 Minute(Rev. 1.1)
 Durability (Life Test): 1500 Cycles
 Insertion Force: 35 Newton Maximum.
 Extraction Force: 10 Newton Minimum.

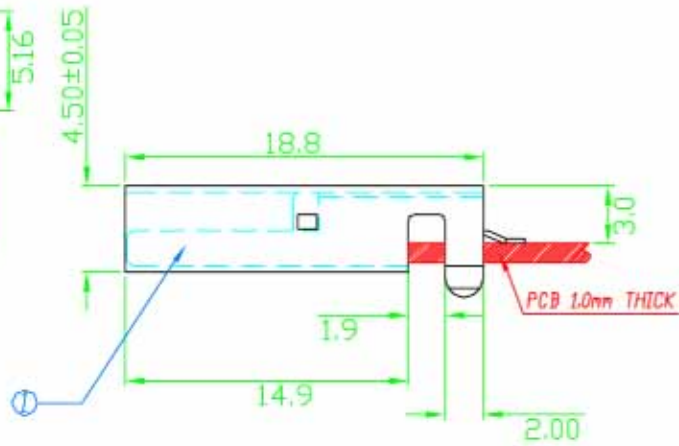

REV	ZONE	REVISION	DATE

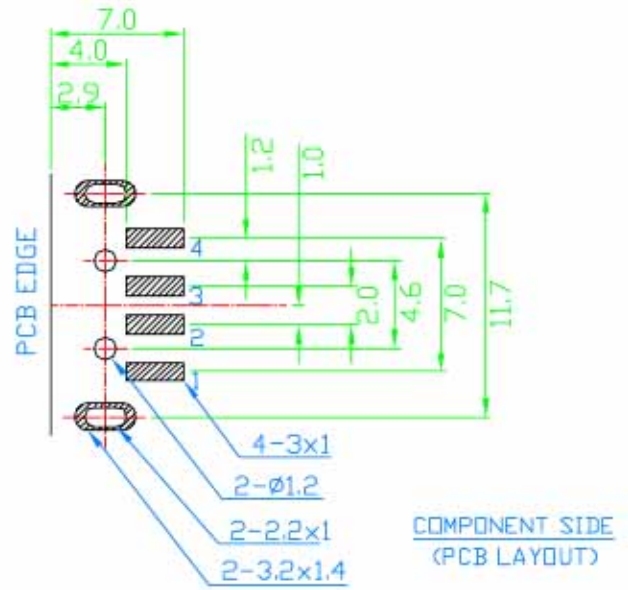

COMPONENT SIDE
(PCB LAYOUT)

NO.	NAME	MATERIAL	FINISH	Q'TY	REMARK
1	HOUSING	NYLON PA9T G.F.	BLACK	1	
2	TERMINAL	BRASS E-H T:0.25	GOLD/TIN PLATED	4	Gold(1~3u'); Ni(40~60u'); TIN(120u') (100% pure Tin of lead free plating)
3	SHELL	BRASS T:0.3	NICKEL PLATED	1	Ni(80~120u')