

毅永企業有限公司 E-YUNG ENTERPRISE CO., LTD.

REV	ZONE	REVISION	DATE

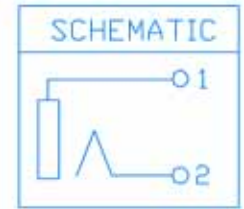
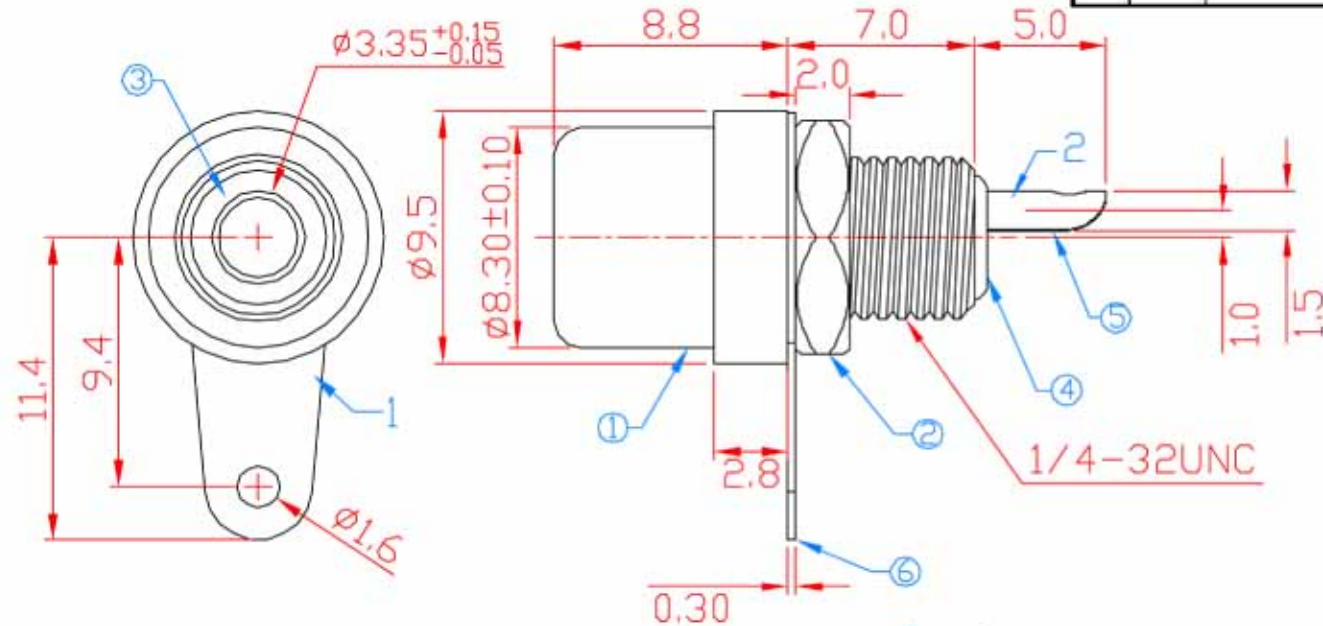

NO.	NAME	MATERIAL	FINISH	Q'TY
1	BARREL	BRASS	NICKEL PLATED	1
2	NUT	BRASS	NICKEL PLATED	1
3	INSERT RING	PBT G.F.	Y.W.R.B.BL.DR.GR	1
4	INSULATOR	PBT G.F.	Y.W.R.B.BL.DR.GR	1
5	TERMINAL	BRASS T:0.25	TIN PLATED	1
6	WASHER	BRASS T:0.3	NICKEL PLATED	1

Specification:

- Contact Resistance: 30m Ohm. Max. At AC 100mA Max.1KHz
- Insulation Resistance: 100M Ohm Min. At 500V DC.
- Rated Voltage And Current: DC 12V,2A Max ; AC 100V,1A Max.
- Dielectric Withstanding Voltage: 500VAC At 60Hz For 1 Minute
- Durability (Life Test): 4000 Cycles
- Insertion Force: 0.3~3.0 Kg.
- Extraction Force: 0.3~3.0 Kg.