

毅永企業有限公司 E-YUNG ENTERPRISE CO., LTD.

REV	ZONE	REVISION	DATE

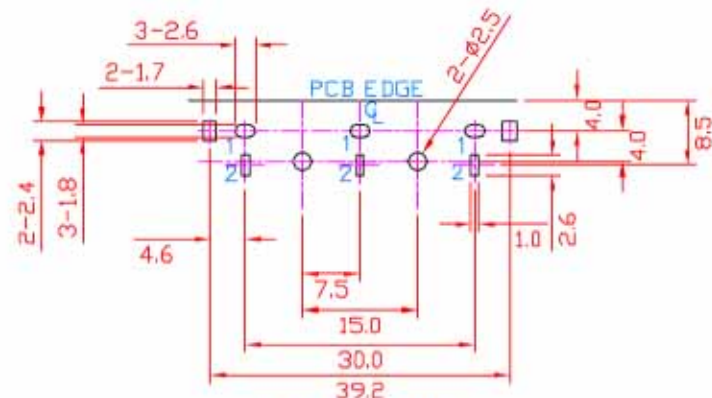

PCB LAYOUT
(BOTTOM VIEW)

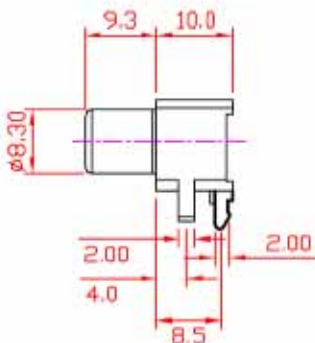
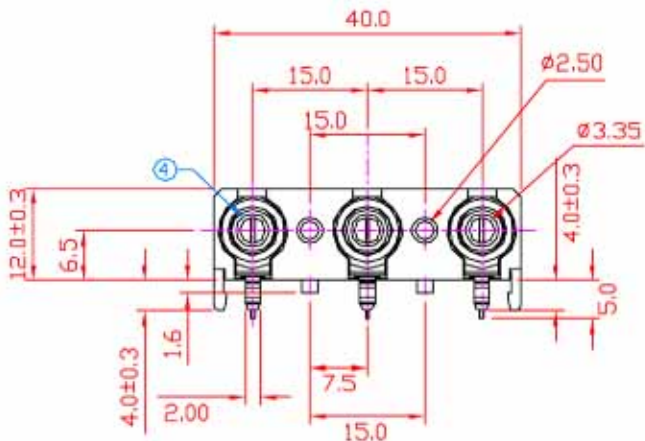
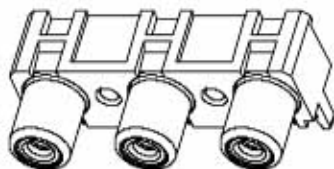
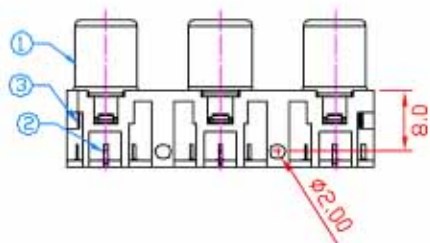

Specification:

- Contact Resistance: 30m Ohm. Max. At AC 100mA Max.1KHz
- Insulation Resistance: 100M Ohm Min. At 500V DC.
- Rated Voltage And Current: DC 12V,2A Max ; AC 100V,1A Max.
- Dielectric Withstanding Voltage: 500VAC At 60Hz For 1 Minute
- Durability (Life Test): 4000 Cycles
- Insertion Force: 0.3-3.0 Kg.
- Extraction Force: 0.3-3.0Kg.

YELLOW WHITE RED

INSERT RING COLORS

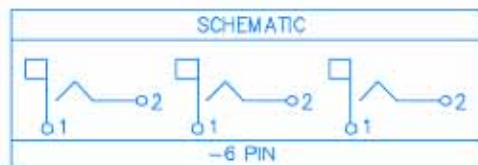

NO.	NAME	MATERIAL	FINISH	Q'TY
1	BARREL	BRASS T:0.4	NICKEL PLATED	3
2	SPRING TERM.	PBS T:0.25	TIN-PLATED	3
3	HOUSING	PBT G.F.	YELLOW	1
4	INSERT RING	PBT G.F.	YELLOW,WHITE,RED	3