

# 毅永企業有限公司 E-YUNG ENTERPRISE CO., LTD.

REV	ZONE	REVISION	DATE

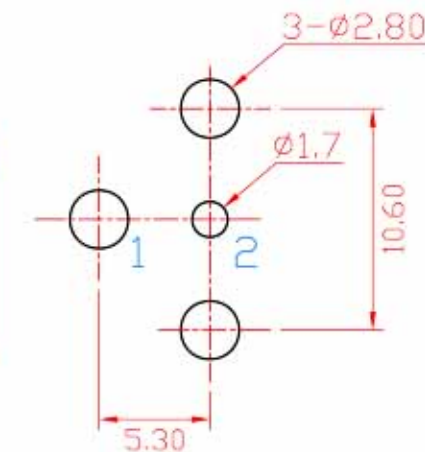
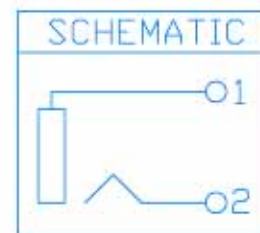
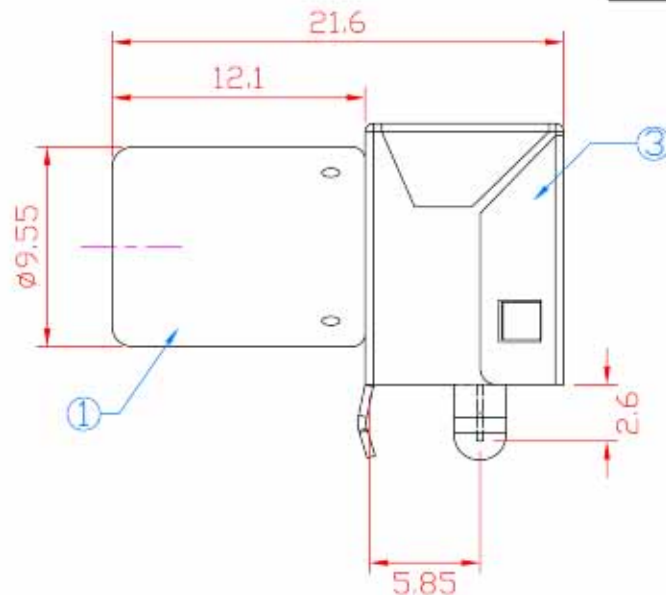
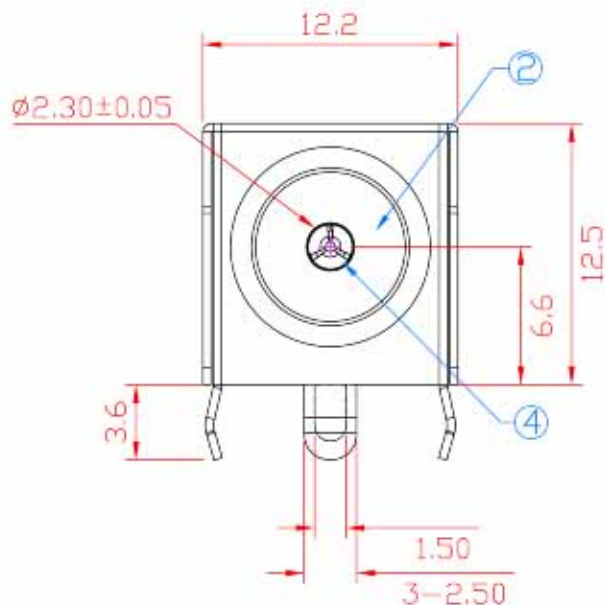

RECOMMENDED PCB LAYOUT

NO.	NAME	MATERIAL	FINISH	Q'TY
1	BARREL	SPCC T=0.3	NICKEL PLATED	1
2	INSULATOR	EPOXY RESIN(FR-4)	WHITE	1
3	FRAME	SPCC T=0.40	NICKEL PLATED	1
4	CENTER PIN	BRASS T=0.30	TIN PLATED	1

## Specification:

Contact Resistance: 50m Ohm Max.

Insulation Resistance: 500M Ohm Min. At 500V DC.

Dielectric Withstanding Voltage: 500VAC For 1 Minute.

Insertion Force: 4.0Kg±2Kg.

Extraction Force: 4.0Kg±2Kg.