

RoHS Compliance

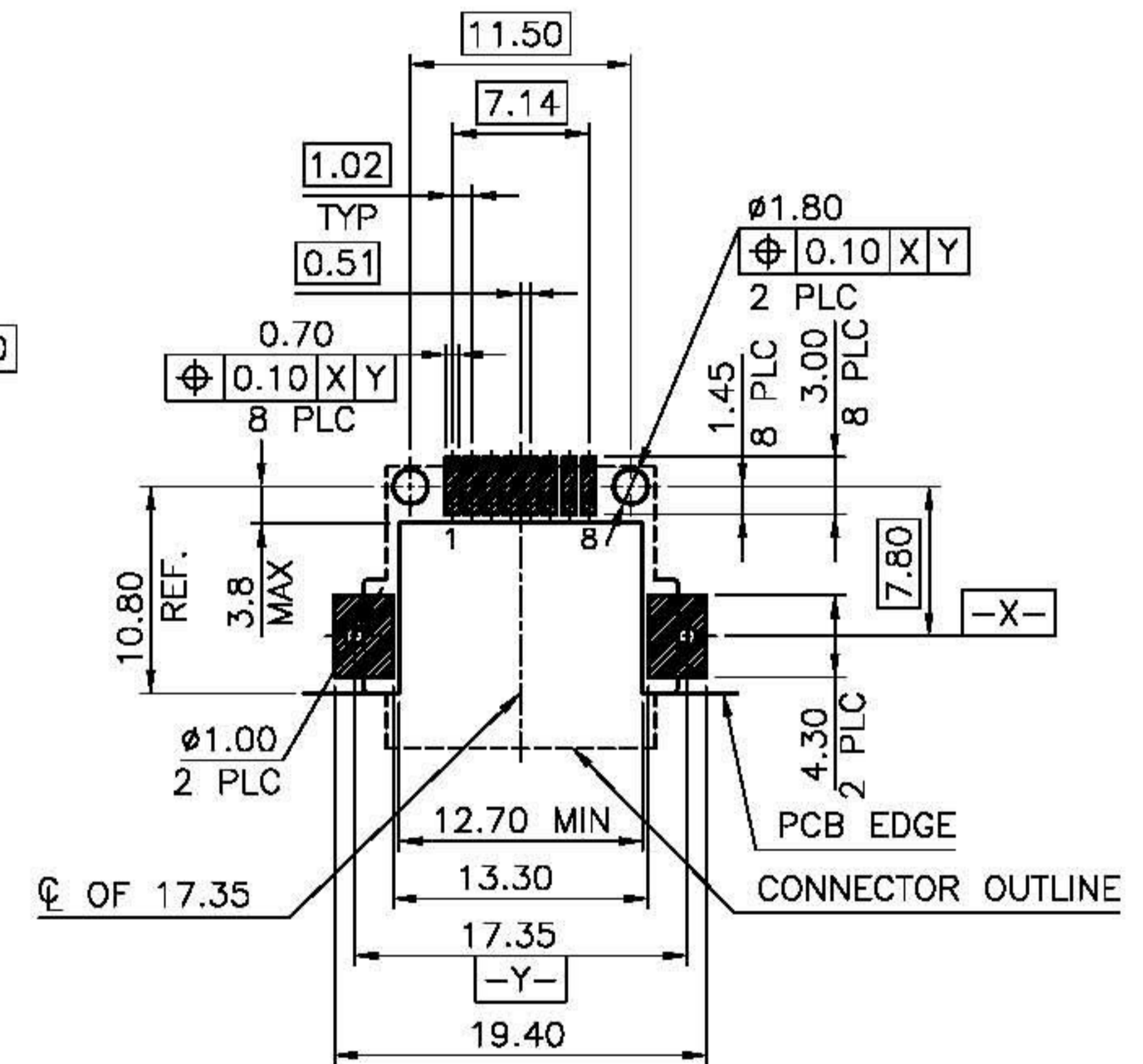

RECOMMENDED PCB LAYOUT
 TOLERANCE: ±0.05 (TOP VIEW)
 RECOMMENDED PCB THICKNESS: 1.2mm.

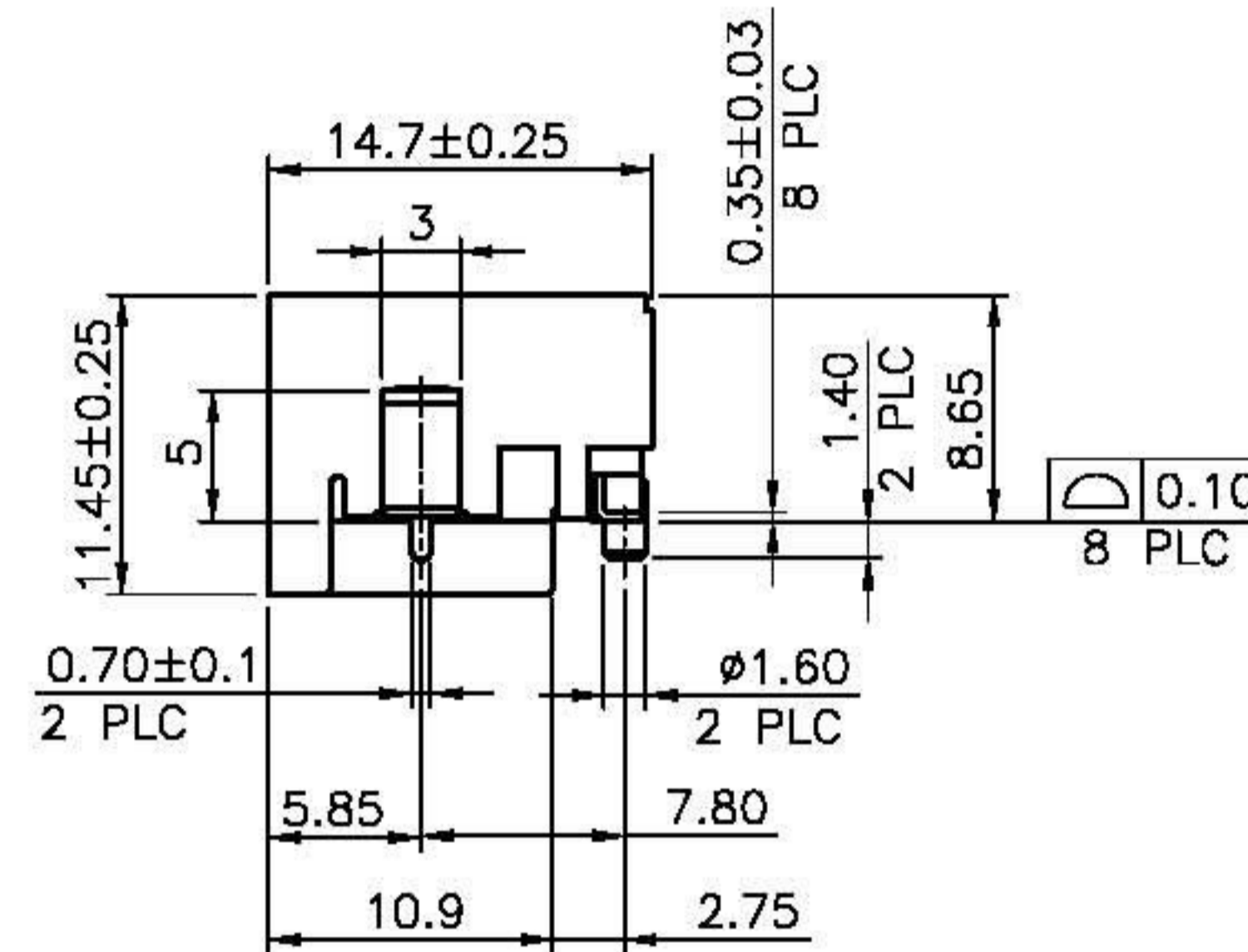
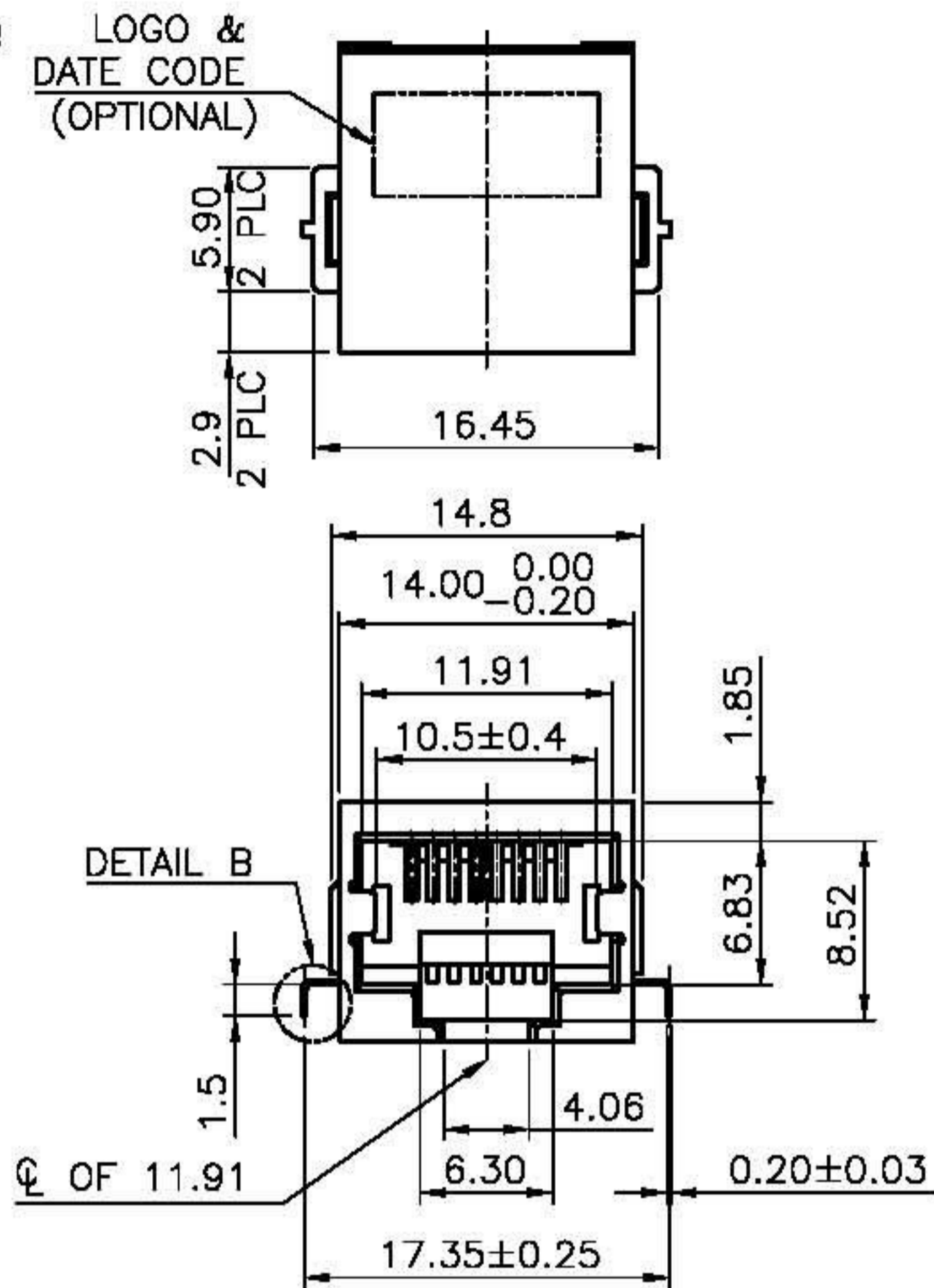
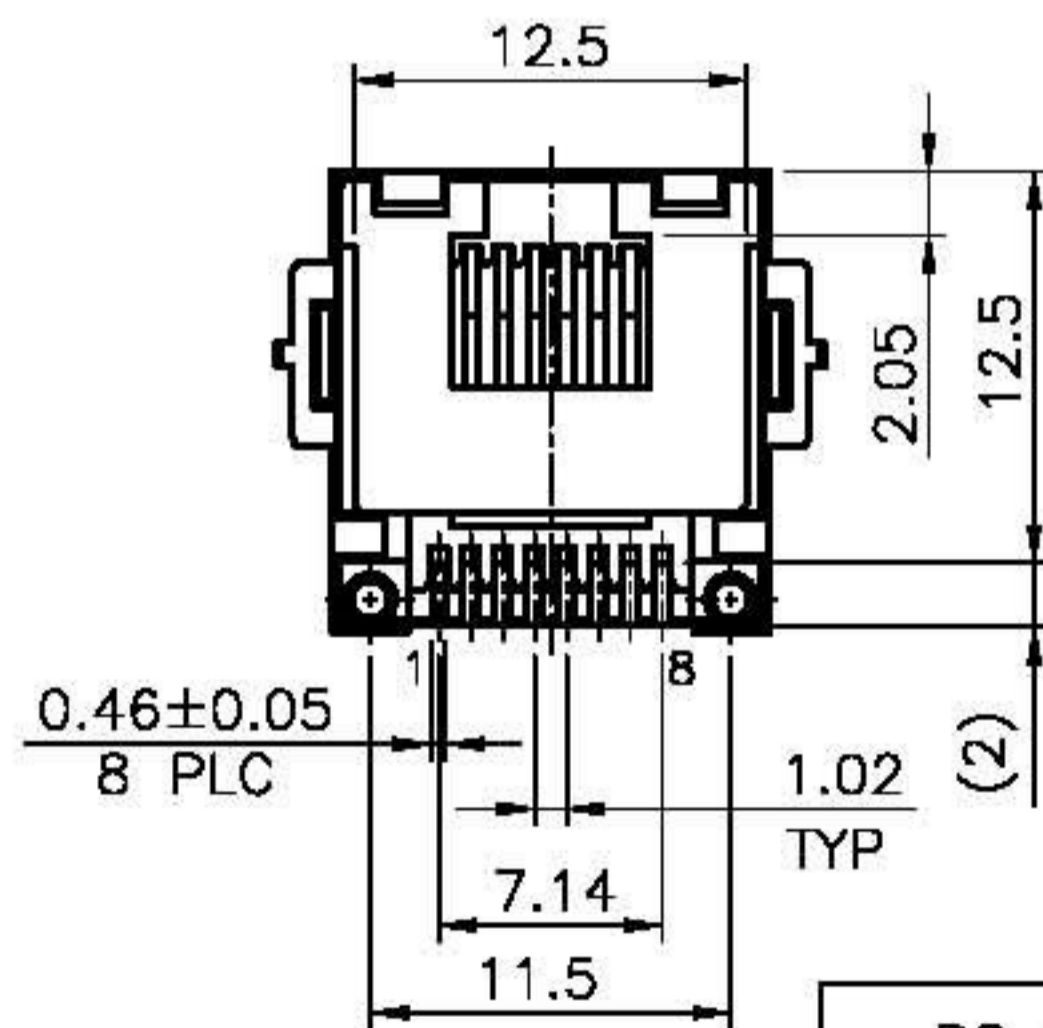
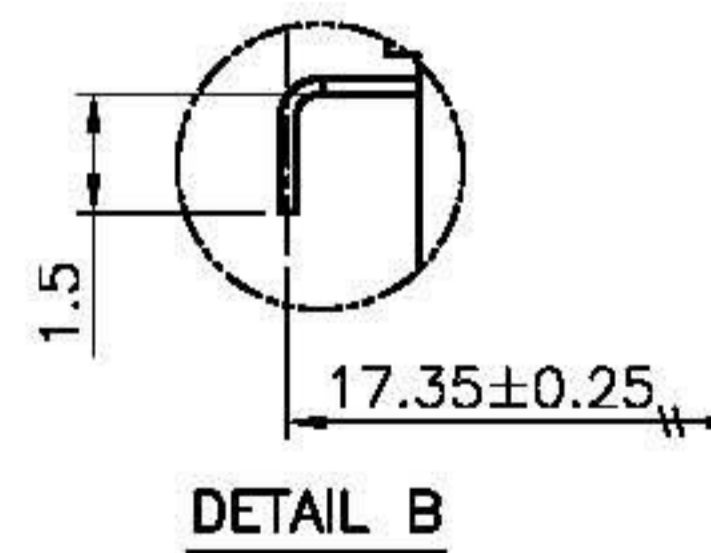

DATE CODE 說明
 XXXXXX
 年 週 序 星
 份 數 號 期
 (班 號 數)
 別

範例: 0926D4
 2009 第 早 星
 年 26 期
 週 班 三

DO NOT SCALE DRAWING	TOLERANCES UNLESS OTHERWISE NOTED	INCH	MM	DR. M.L.HUANG	DATE AUG-24 '09
THIRD ANGLE PROJECTION	LINEAR MM INCH	00 ± .01 000 ± .005 0000 ± .002	0.0 ± 0.25 0.00 ± 0.13 0.000 ± 0.05	CK'D M.CHANG	AUG-24 '09
MM INCH	ANGLE ± 0° 30'	RADII	+0.40 -0.15	APP'D W.J.YANG	AUG-25 '09

E-YUNG ENTERPRISE CO., LTD.					
TITLE		MODULAR JACK RJ45 SMT CONNECTOR			
SCALE	SIZE	DWG.NO.	REV.	SHEET	
		984604	2	1	