

1. Functional spec.			
1.1 Rated Voltage	250VAC	1.6 Free Position	12.5±0.5mm
1.2 Rated Current	5A	1.7 Operating Position	11.5±0.5mm
1.3 Contact Resistance	≤50mΩ (Initial value)	1.8 Position Travel	
1.4 Operating Force	(××) gf	1.9 Return Force	
1.5 Bounce Time		1.10	

2. Reliable Rating			
2.1 Mechanical Life	100,000 CYCLES	2.5 Hand Soldering Temper	380°C Max; 3 second
2.2 Electrical Life	10,000 CYCLES	2.6 Operating Temper	-15°C - +70°C
2.3 Insulation Resistance	≥100MΩ DC500V (Initial value)	2.7 Shipping/Storage Temper	-25°C - +80°C
2.4 Withstand Voltage	AC1000V 1 minute (Initial value)	2.8 Ambient Humidity Used	<85%RH

3.1 protection against ingress of dust ≤Φ1.0mm (IP5X)	<p>The switches are placed in a position of normal use inside the test chamber. The test is carried out according to the second enclosure of IEC60529-1989. The test shall be continued for a period of 8h. After testing, the switches are taken out of the chamber and left at 25±10°C conditions, Load Rating: 5A 250VAC, test the temperature rise of the switches.</p>	<p>After test:</p> <ol style="list-style-type: none"> 1. Operating is normal; 2. The temperature rise shall not exceed 50K; 3. Between terminals, terminal and surface of the crust, dielectric withstand in voltage ≥1000V
3.2 protection against ingress of water (IPX1)	<p>The switches are placed in an oven which the temperature is 70±2°C for 240 hours. Then the switches are taken out of the oven immediately and left at 25±10°C conditions for 16 hours. After that, testing protection against ingress of water. During the testing: the temperature between the water and the samples shall not exceed 5K, and the switches have no electric current.</p>	<p>After test:</p> <ol style="list-style-type: none"> 1. The body of the switch and the airproof cap have no transmutation, dilapidation, induration; 2. The switch shall withstand the dielectric strength ≥1000V 3. There is no trace of water on insulation which could result in a reduction of creepage distances and clearances below the values specified.
3.3 reference standards and conditions	<p>IEC60529-1989 IEC61058-1:1996 Environment condition: temperature rang 15°C-35°C.</p>	

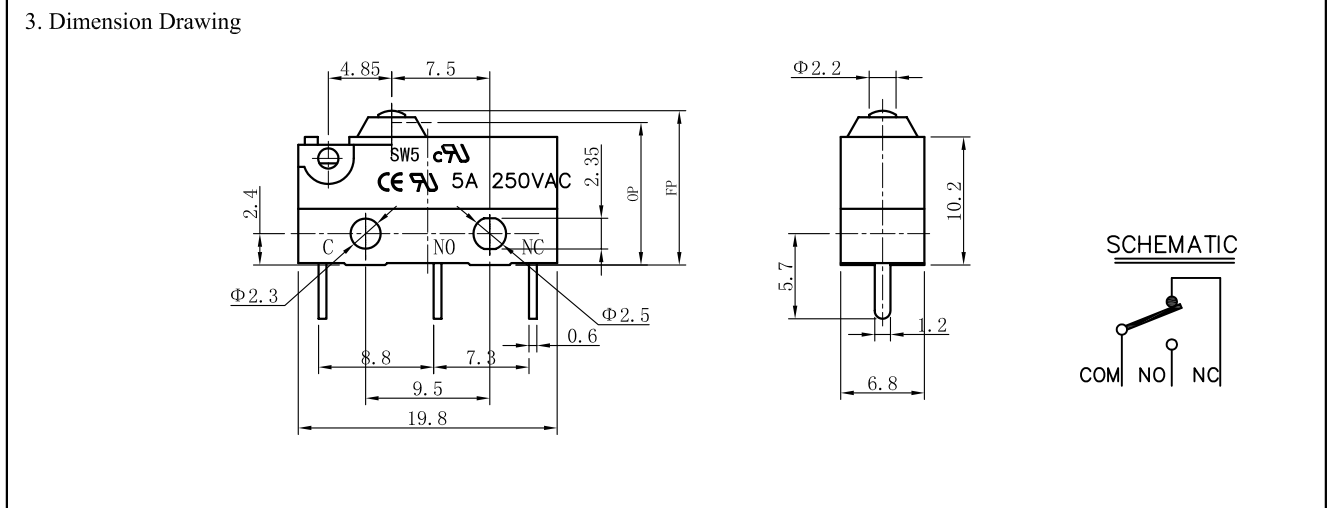

Revision	Description	Date	Revisor
Drawing No.		C/0	Tolerance ±0.2
Drawing Model.	SPECIFICATION OF STANDARD TYPE		Unit mm
Prepared	Reviewed	Approved	Effective date