

REV.	DESCRIPTION	CHANGE BY	APPL. BY	DATE
A				
B				
C				

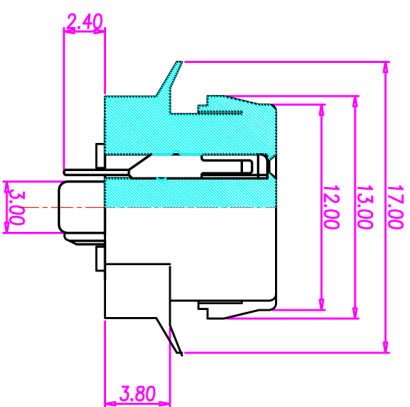
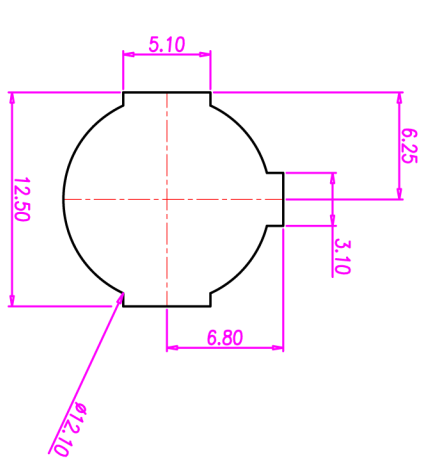
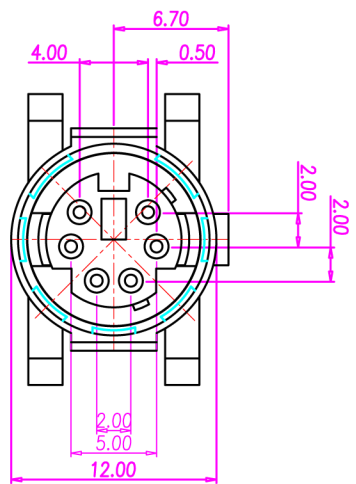
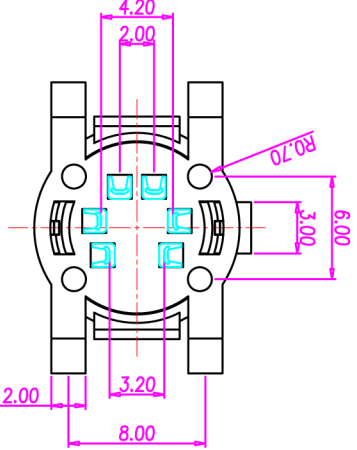
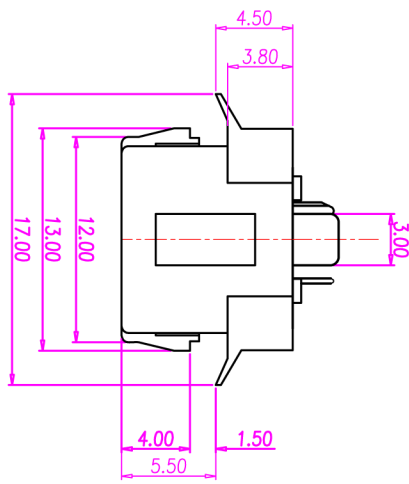

備註 /NOTE:

1. 材質 /MATERIAL:
 - 1-1. 銅管 /SHELL: 磷銅 /PHOSPHOR BRONZE
 - 1-2. 膠芯 /HOUSING: PBT+15%GF UL94V-0
 - 1-3. 端子 /PIN: 磷銅 /PHOSPHOR BRONZE
2. 電鍍 /PLATING:
 - 2-1. 銅管 /SHELL: 亮錫 50u"/TIN 50u"
 - 2-2. 端子 /PIN: 銀30u"/Silver 30u"

繪圖 DRAW. BY	日期 DATE	單位 UNIT	一般公差 一般公差 .x ±0.25 .xx ±0.10	品名 ITEM	料號 PART NO.	圖號 DWG NO.	QC3081	SHEET SIZE A4
Angus	09/27/07	mm		MINI DIN 6PIN (F) 扣板式	MD-06F2-04			
校核 APPVL. BY	版本 VERSION	比例 SCALE						
Frank	ORIG	1:1						