

REV.	DESCRIPTION	CHANGE BY	APPVL BY	DATE
A				
B				
C				

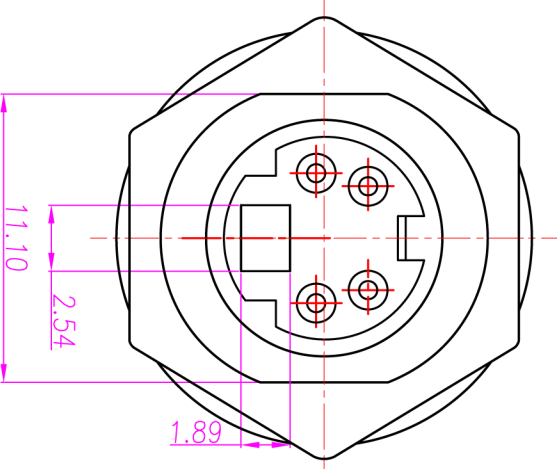
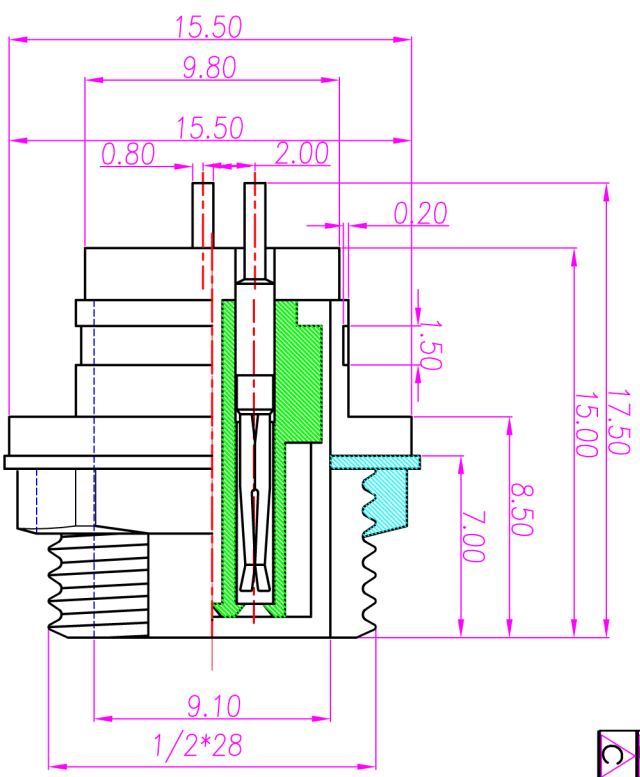
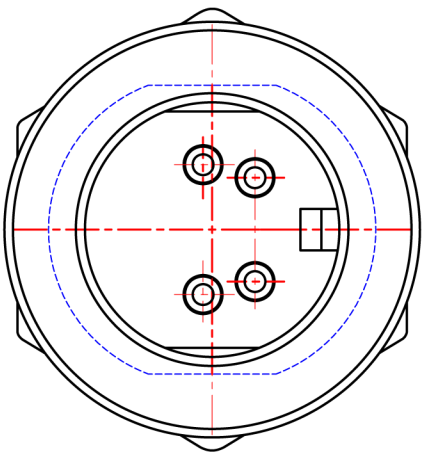

備註 /NOTE:

1.材質 /MATERIAL:

- 1-1 膠芯 /HOUSING: PBT+30%GF
- 1-2 端子 /PIN: 磷銅 /PHOSPHOR BRONZE
- 1-3 銅殼 /SHELL: 黃銅 /BRASS
- 1-4 墊片 /SPACER: 不銹鋼
- 1-5 螺母 /SCREW: 黃銅 /BRASS

2.電鍍 /PLATING:

- 2-1 端子 /PIN: 表金/GOLD FLASH
- 2-2 銅殼 /SHELL:SEE TABLE A
- 2-3 墊片 /SPACER: SEE TABLE A
- 2-4 螺母 /SCREW: SEE TABLE A

TABLE A

ITEM	品名	料號	圖號
MD-04F2-08	MiniDin 4(F)板端+六角螺母		
MD-04F2-02	MiniDin 4(F)板端+六角螺母	表金 /GOLD FLASH	
P/N	DESCRIPTION	鍍/Ni	PLATING

繪圖 DRAW BY	Angus	日期 DATE	05/04/06	單位 UNIT	mm	一般公差 TOLERANCE	±0.10 ±0.05	圖號 DWG NO.	QC2200	圖號 DWG NO.	QC2200	圖號 DWG NO.	QC2200	圖號 DWG NO.	QC2200
校對 APPVL BY	Frank	版本 VERSION	1	比例 SCALE	1:1	公差 TOLERANCE	±0.10 ±0.05	料號 PART NO.	SEE TABLE A	圖號 DWG NO.	QC2200	圖號 DWG NO.	QC2200	圖號 DWG NO.	QC2200