

# CUSTOMER DRAWING

REV.	DESCRIPTION	APPL. BY	DATE	ECN NO.
A	RELEASE	Fido Veng	24/02/09*	
B	RELEASE	Fido Veng	07/05/10*	
C				

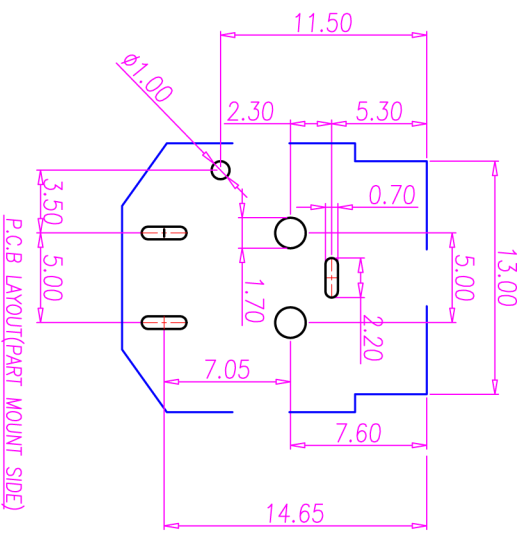
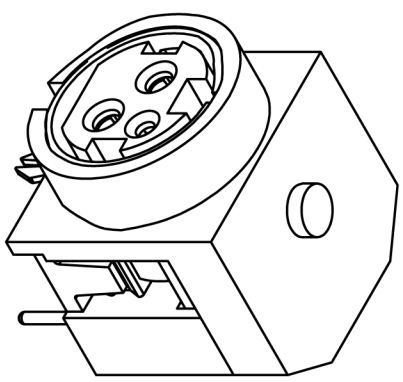
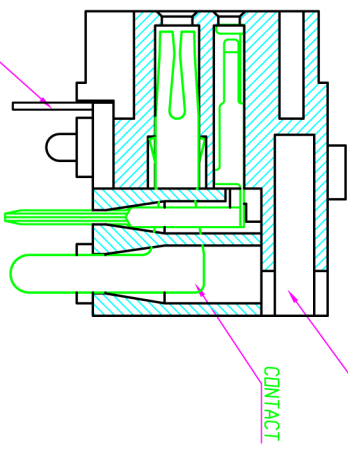
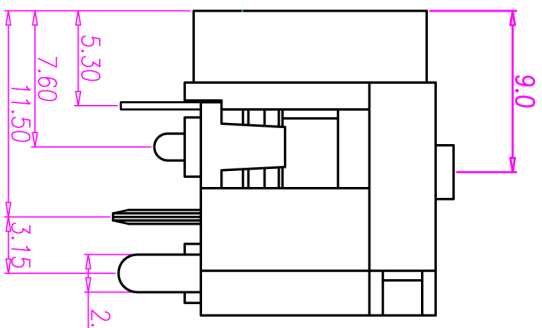
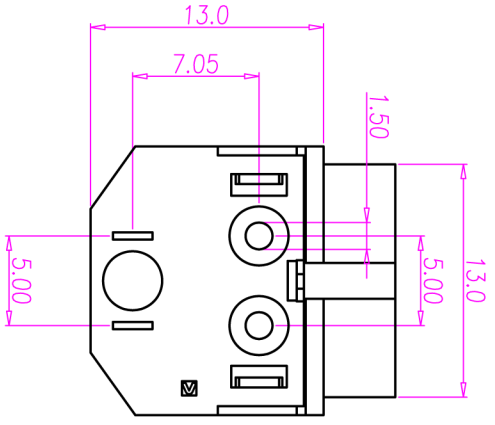
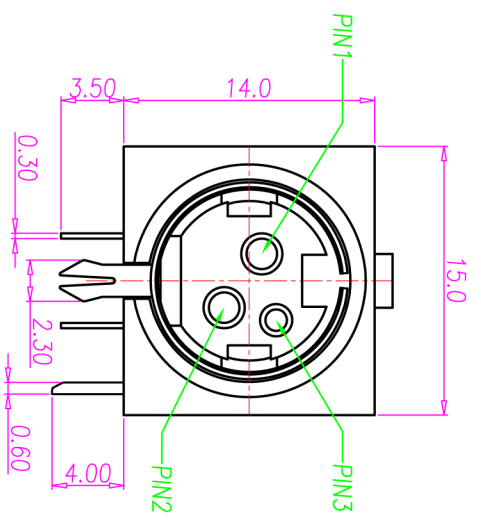

1. MATERIAL :
  - 1-1. HOUSING : SEE TABLE A
  - 1-2. CONTACT : PHOSPHOR BRONZE
  - 1-3. SHELL : BRASS
  - 1-4. BACK COVER : SEE TABLE A
2. FINISH :
  - 2-1. CONTACT : 30 MICRO INCHES MIN. SILVER PLATING OVER NICKEL
  - 2-2. SHELL : NICKEL PLATED 60u" ~ 100u" OVER ALL
3. ELECTRICAL SPECIFICATION :
  - 3-1. RATED CURRENT : PIN1 & PIN2 : 7.5A  
PIN3 : 1A
  - 3-2. RATED VOLTAGE : 20V DC
4. ENVIRONMENTAL :
  - 4-1. OPERATION TEMPERATURE : -20 °C~85°C

TABLE A

PART NO.	HOUSING & BACK COVER
PD-03F2-01	PBT UL94V-0
PD-03F2-05	LCP UL94V-0

DRAW	Ren Luo	APPL	Fido Veng	UNIT	mm	TOLERANCE	 				
CHECK	Emily Suen	SCALE	1:1	SCALE	1:1	x ±0.20 xxx ±0.15 xxxxx ±0.10 ANGLE ±1°					
TITLE		PART NO.		SEE TABLE A		DVG NO.		QC0358		SHEET	
PowerDin 3(F) 插頭DIP										VERSION	
										B	