

REV.	DESCRIPTION	CHANGE BY	APPVL. BY	DATE
△	尺寸變更	Vincent	Frank	04/05/20

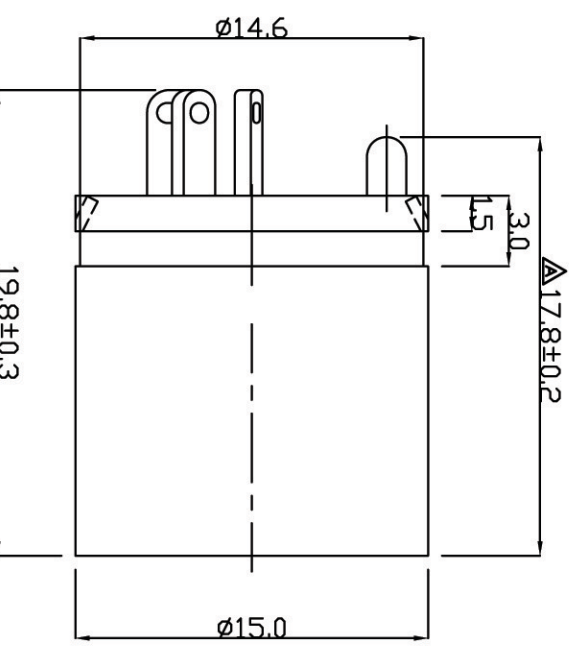
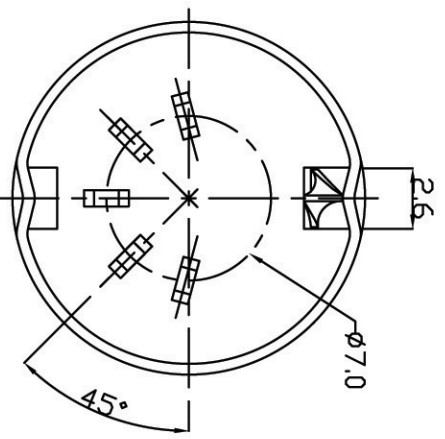

備註/NOTE:

1. 安規/SAFETY:
 1-1. 規格/RATING: 100V AC MAX or 12V DC 2A MAX
 1-2. 絕緣阻抗/INSULATION RESISTANCE: 50MΩ MIN at 250V DC
 1-3. 絕緣耐壓/WITHSTANDING: 250V AC at 1 MINUTE
2. 材質/MATERIAL:
 2-1. 膠芯/HOUSING: PBT+30%GF UI94V-2 (黑色/BLACK)
 2-2. 針/PIN: 黃銅/BRASS
 2-3. 銅管/SHELL: 黃銅/BRASS
 2-4. 彈片/SPRING: 磷銅/PHOSPHOR BRONZE
3. 電鍍/PLATING:
 3-1. 針/PIN: SEE TABLE A
 3-2. 銅管/SHELL: 鍍/NICKEL
 3-3. 彈片/SPRING: 銀/SILVER
4. 使用環境/OPERATING RANGE: -20°C to 105°C
 5. 插入力/INSERTION FORCE: 41B(1.8KGF)-81B(3.6KGF)

TABLE A

料號	品名	系列	鍍
D1-05F1-02	D5 S 錫(內)成品		錫/TIN
D1-05F1-01	D5 S 銀(內)成品		銀/SILVER
P/N	DESCRIPTION		針 電鍍

繪圖 DRAW. BY Ellen	日期 DATE 05/15/01	單位 UNIT MM	一般公差 TOLERANCE X ±0.1 .XX ±0.05	圖號 DWG NO. QC0114	品名 ITEM D5 S (內)成品	系列 S	圖號 DWG NO. QC0114	圖號 DWG NO. QC0114	尺寸 SIZE A4
審核 APPVL. BY Frank	版本 VERSION A	比例 SCALE 3:1		料號 PART NO.	SEE TABLE A				